

[www.schaltbau-bode.com](http://www.schaltbau-bode.com)



**Bode. Die Tür.**  
System solutions for rolling stock.





# This much. is certain.

## Industrial production – Made in Germany

- excellent quality due to advanced production
- cost efficient lean-production
- high degree of automation

## Standardised components & systems

- entrance systems – electric, pneumatic & mechanical
- extensively validated components and systems
- comprehensive documentation, approvals and certifications

## In-house software development & support

- HARDI & MTB3 diagnostics & control management systems
- BMUplus, the Bode Boarding Management Unit
- high degree of system compatibility thanks to in-house development

## Efficient & long-term cooperation

- designated partners in many countries
- customer and result orientated
- high level of know-how due to low employee fluctuation

## Life-cycle costs

- market-driven prices for a product life – thanks to high quality, long & reliable useful life and effective service
- compliant and flexible to your requirements

## Knowledge at the interface with the passenger

- exchange with user groups and associations
- research & development collaboration with institutions and universities

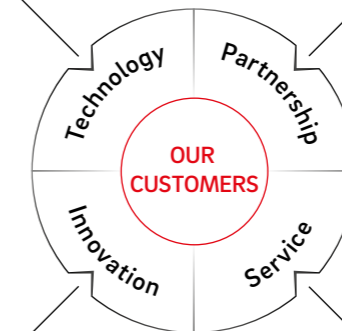

## Less weight, more stability, compact design

- use of aluminium & composites with simultaneous increase in stability and useful life
- "Plug & Play" – small installation spaces and short installation times

## Trend-setting development

- e-mobility pioneer
- development expertise for the highest requirements
- intelligent sensors and networked systems

## Schaltbau Group – taking the vehicle to the next level

- cross-system products and intelligent sensors
- long-term availability of systems and services
- leader of new technologies and initiator of trends

## Fast response and uncompromising commitment

- worldwide services
- direct contact and availability
- fast-response problem solving

## Easy maintenance

- service-friendly design
- intelligent diagnostics
- multi-lingual technical documentation

## Smooth logistics

- just-in-time – assembled to your specifications
- reusable transport racks
- long-term reliable and fast spare parts logistics



## We are. intelligent. Engineering.

### Industrial precision

Dimensional accuracy and reliable function during their entire life are elementary components of our door systems. We achieve these quality levels by consistently investing in our production. In our Kassel location we produce solely to lean criteria – partly standardised, partly fully automated, but always high precision. In this way we ensure that our products do precisely what is expected of them, even under long-term sustained loads.

### Customer-focussed strengths

When developing door systems we are never satisfied with anything less than the best solution. Bode has numerous patents in kinematics, electrical drives and networked systems. We dedicate the same technical expertise on which these developments are based to each further project too. Uncompromising reliability throughout the entire product life cycle is the result of Bode's comprehensive design and testing process. For each of our products we verify the safety of the concept (FMEA) in hardware and software on the basis of legal regulations and individual standards.

### Exclusive software solutions

Software must work. It does it best if the development is precisely matched to the installed components and the mechanical requirements in the door system. This is the task of Bode's software development department. Working in close consultation with all functional departments, we develop individual software applications, which are used exclusively for each system.

### Fulfilled user needs

The door is the interface with the passenger. For us it is obligatory that we bear in mind the needs of these stakeholders at all times. Safety and comfort always come first. In our projects we always have an eye on trends and wishes, as well as future measurement technology and sensors and we incorporate our cross-industry know-how from the rail, bus and automotive sectors into our realisation of the optimum solution.



## We are. cooperative. Partnership.

### Efficient collaboration

For us results-orientated working means completing projects quickly and cleanly in consultation with our customers. We bring together all the requirements for achieving this in our project management. We assign fixed contacts to each customer, who are then responsible for providing support, ensuring all workflows run smoothly and speak the same language as the customers – technically, interpersonally, but also in the true sense of the word: We develop fast and adapted solutions in many languages, experienced and confident on the national and international stage.

### Flexible organisation

In collaboration with our customers we strive to achieve a long-term partnership. To this end above all we pledge to achieve maximum on-time delivery, constant quality and binding cost structures. One of our other strengths is to respond flexibly and pragmatically to wishes and changes during the project. This is made possible by many years of experience, short decision-making channels and a performance-orientated corporate culture.

### Transparent costs structure

Our customers value Bode products due to their high, above-average reliability in use. Our brand stands for these strengths since many years. From the initial development to the worldwide sourcing of materials through to series production – our objective is to achieve the highest possible quality. Our goal is always: maximum reliability for minimum life-cycle costs.

### Mutual exchange

Regular meetings with representatives of passenger associations and other institutions give us insight, not only into current developments. This mutual exchange promotes understanding and helps us to safeguard and to take into account the interests of passengers and associations from the early product planning stage. Keeping this in mind from the outset gives us and our customers the certainty that ultimately nothing has been forgotten.



## We are. inspirational. Innovation.

### Innovative partnership

When it comes to developing new systems and solutions, we like to be on board from the outset. For 50 years, Bode has been an innovation driver in the industry. We hold numerous patents which substantiate our high degree of technical excellence. If necessary our customers can rely on these resources exclusively for the development of new systems for doors, sliding steps and software. Together with the Schaltbau Group and the cross-industry collaboration of our areas of business, we continuously raise our innovation potential to a new level. This makes us the first choice for many for new product development – as a reliable partner from the design through to the finished solution.

### Forward-looking development

eMobility, electric drives and networked systems, whether online or offline, are the topics to which the future belongs. We are already working intensively on the most important aspects, which in a few years will have a decisive influence on the transport of people and goods. The world is becoming “smart”. Previously unimagined opportunities are opening up for innovative product solutions. However, these are raising new challenges regarding security and data protection, which must also be solved. Research and development – cross-industry and with an ear to the market – is our approach to dealing with these issues, and at the same time to engage in close knowledge transfer with our customers.

### Reduced weight

Lightweight construction is a central innovation driver for us in many areas of development. We continuously find new possibilities for reducing the weight of our door systems through intelligent and innovative use and combination of materials. Lightweight construction expertise is a notion with which we identify ourselves.

### Integrated synergies

As part of the Schaltbau Group we actively transfer knowledge within the Group. Through our close cooperation we understand rolling stock and transport integrally, throughout the vehicle. This know-how enables us to use the available synergies intelligently to reliably include all requirements of a development and to continuously contribute new thought-provoking ideas for new developments and further development of existing systems in the partnership between us and our customers.



## We are. prepared. Service.

### Quick-response service

Our service team supports you throughout the entire life cycle of our systems – from the initial installation in new vehicles through to the overhaul of entire vehicle fleets. We offer training programmes, through which your personnel can ensure economical operation of Bode door systems for a long time. You can reach our team at any time and it can join you to provide on-site support worldwide within a short time. Direct help in all matters is a decisive criterion for us to achieve optimum partnership and reliability.

### Problem-free maintenance

Maintenance and service times should be reduced to a minimum. For this time we pay attention to service-friendly planning and easy accessibility during the design stage, and provide computer-aided maintenance options with our HARDI diagnostics tool. We provide our customers with the technical documentation necessary for maintenance and service with each order, on request this can also be supplied in the respective language of the country of use.

### Smooth logistics

Efficiency is created whether processes mesh seamlessly. In consultation with our customers, we purposefully ensure that our services are as smooth as possible. Under the aspect of service we also pay particular attention to logistics. Above all, this means cost-effective and secure transport of the goods to their intended destination. Together we clarify the requirements and implement them with a high degree of on-time delivery – not only for door systems but also for secured and quick-response supply of spare parts.

# BIDS® S.

## Single panel sliding-plug door systems.

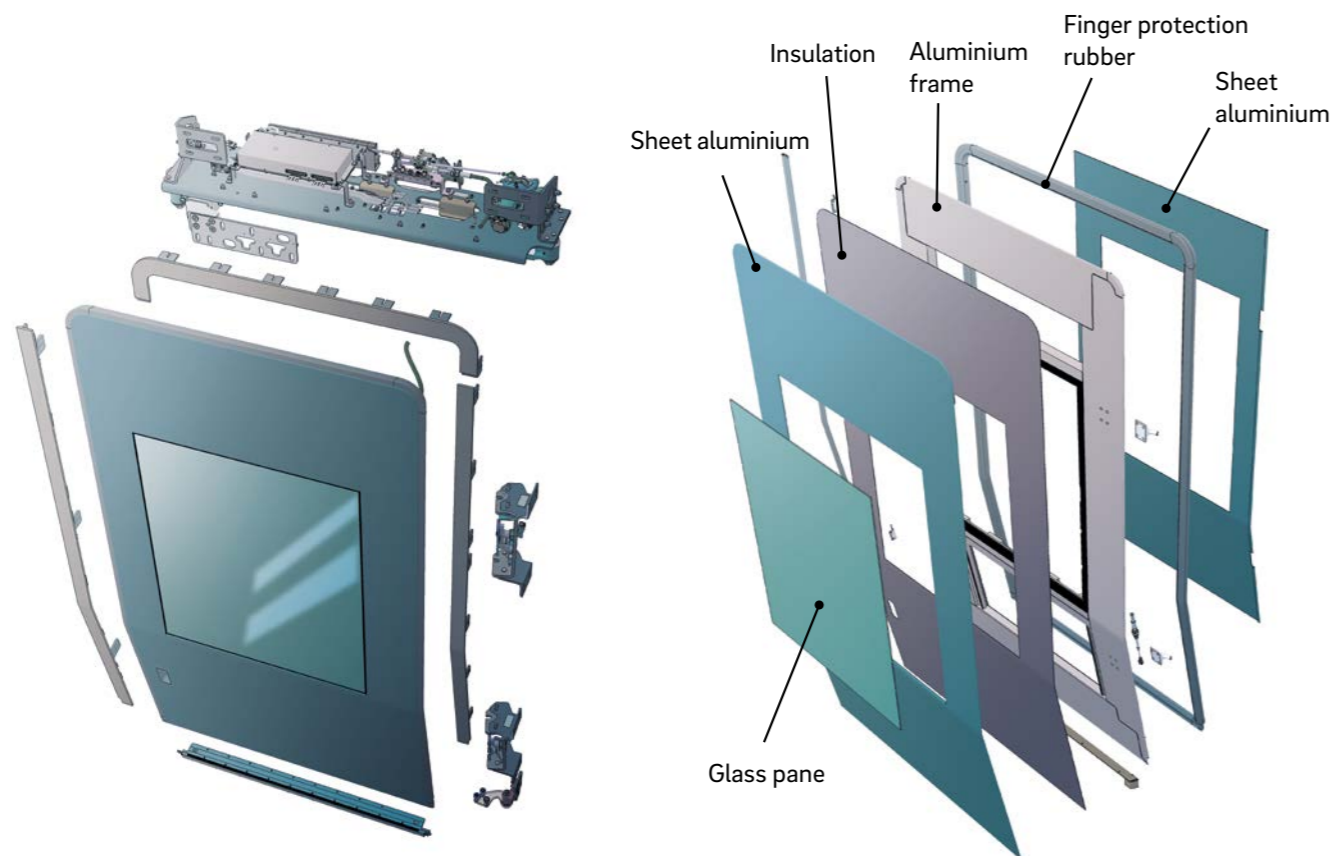

### BIDS® S Single panel sliding-plug door

The BIDS® S sliding-plug doors have been tried and tested in use in LRV systems, regional-, Intercity- and high-speed trains for decades.

### Sandwich door panel

The sandwich design of the door panels enables all kinds of different window shapes. Very good thermal and sound insulation values can be achieved by using additional insulation materials in the door panel configuration.

### Mechanism

The BIDS® S door drives are a match for the daily requirements in public passenger transport and have been tried and tested for decades in many countries. The simple, lightweight and robust design ensures reliability and a high degree of comfort and convenience for passengers and the vehicle operators.

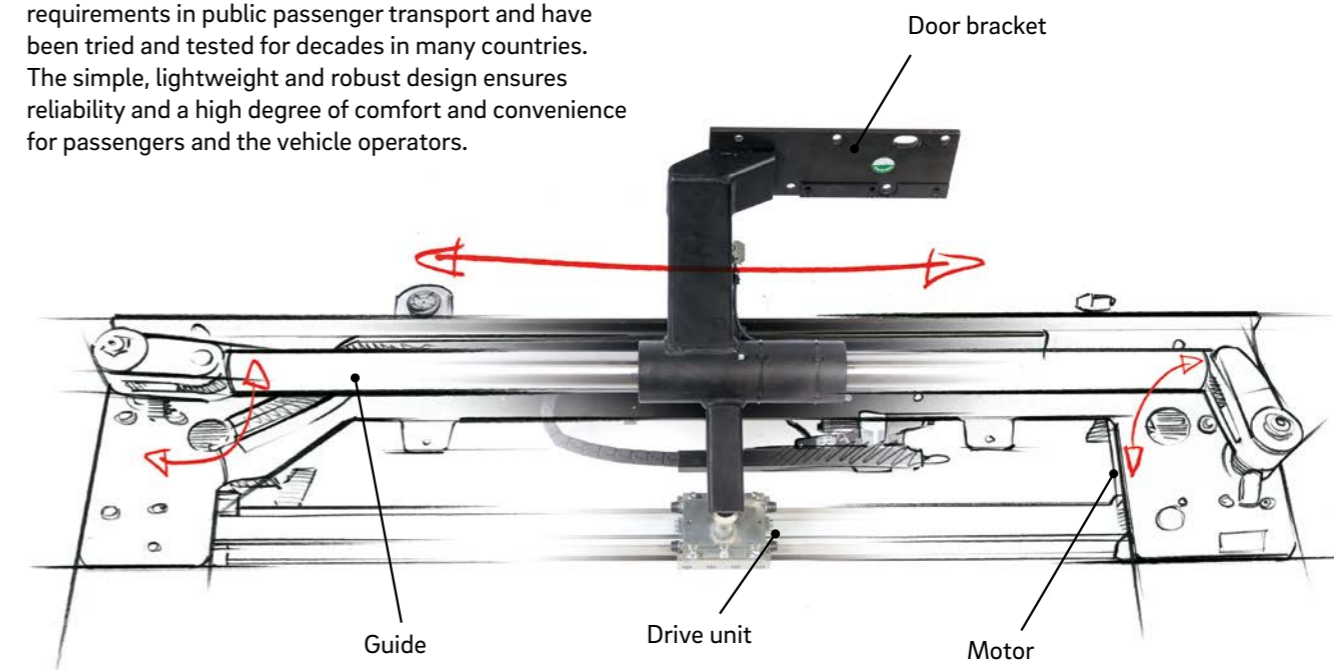

### Locking units

We select the type of locking unit depending on your specific requirements and the loads to be absorbed. Depending on the requirement we secure the door system via a locking column, a lockable swivel arm or a rotary latch lock. The systems are tried and tested and provide optimum safety.

Clear width:	800 – 1,300 mm
Drive:	electric, toothed belt
Energy consumption per operation: (opening and closing)	approx. 150 Ws per cycle (incl. DCU continuous output)
Maintenance frequency:	approx. 50,000 cycles
Use:	LRV, Metro, Regio, IC, HGV
Locking unit:	Over center by means of: Rotary latch via push-pull Bowden cables / locking column / lockable swivel arm
Control unit:	24V / 36V / 72V / 110V
Diagnostics:	USB / ethernet
Sensors:	BMU / electric sensitive edges and light barrier / light grid, motor current sensing and time-path sensor

Locking column



Lockable swivel arm



Rotary latch



**BIDS®.**

# Double panel sliding-plug door systems.

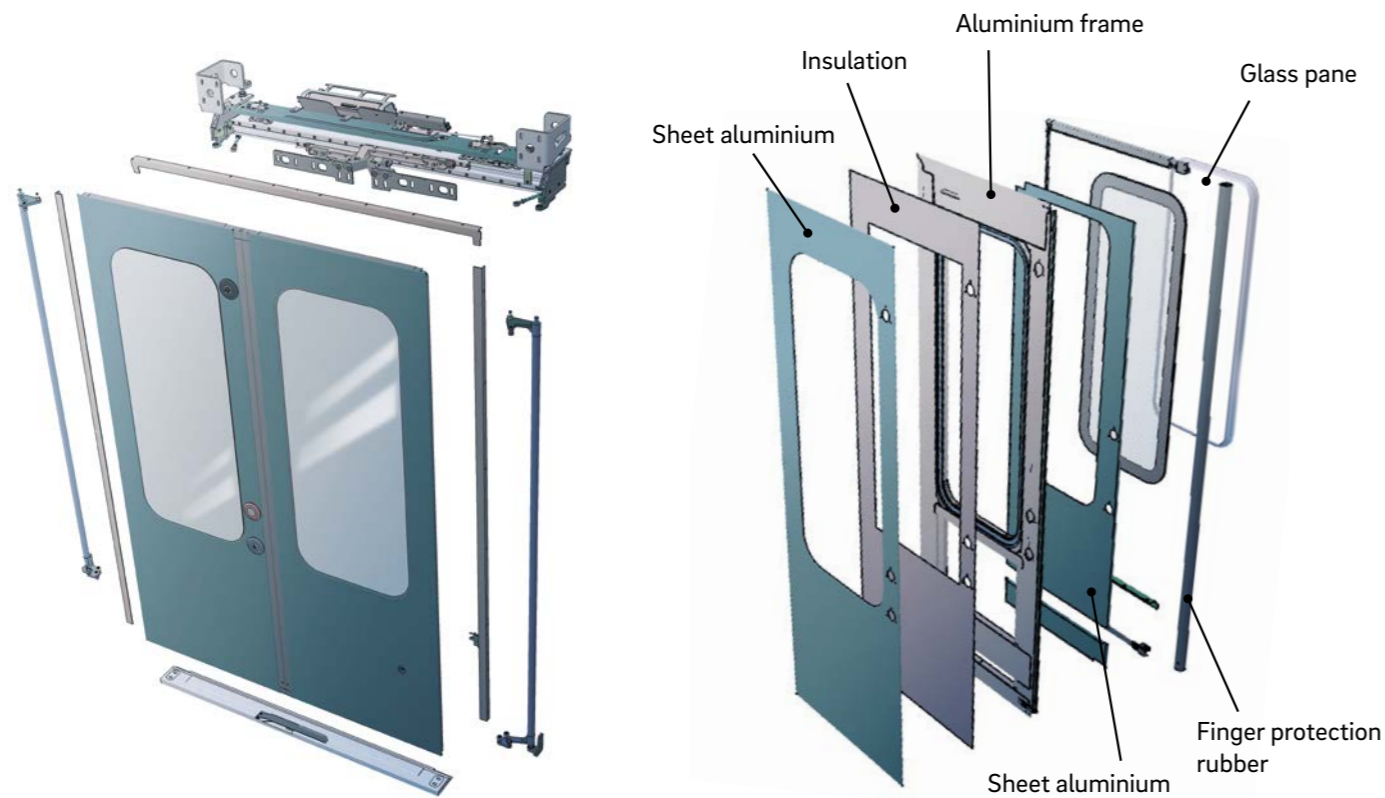

## BIDS® Double panel sliding-plug door

The BIDS® sliding-plug doors have been tried and tested in use in tram systems, metros and regional trains for decades.

## Sandwich door panel

The sandwich design of the door panels enables all kinds of different window shapes. Very good thermal and sound insulation values can be achieved by using additional insulation materials in the door panel configuration.

## Mechanism

The BIDS® door drives withstand the daily requirements in public passenger traffic thanks to the simple and robust design. Combined with intelligent diagnostics and the sensor units they provide the best possible comfort and convenience for entry and exit.

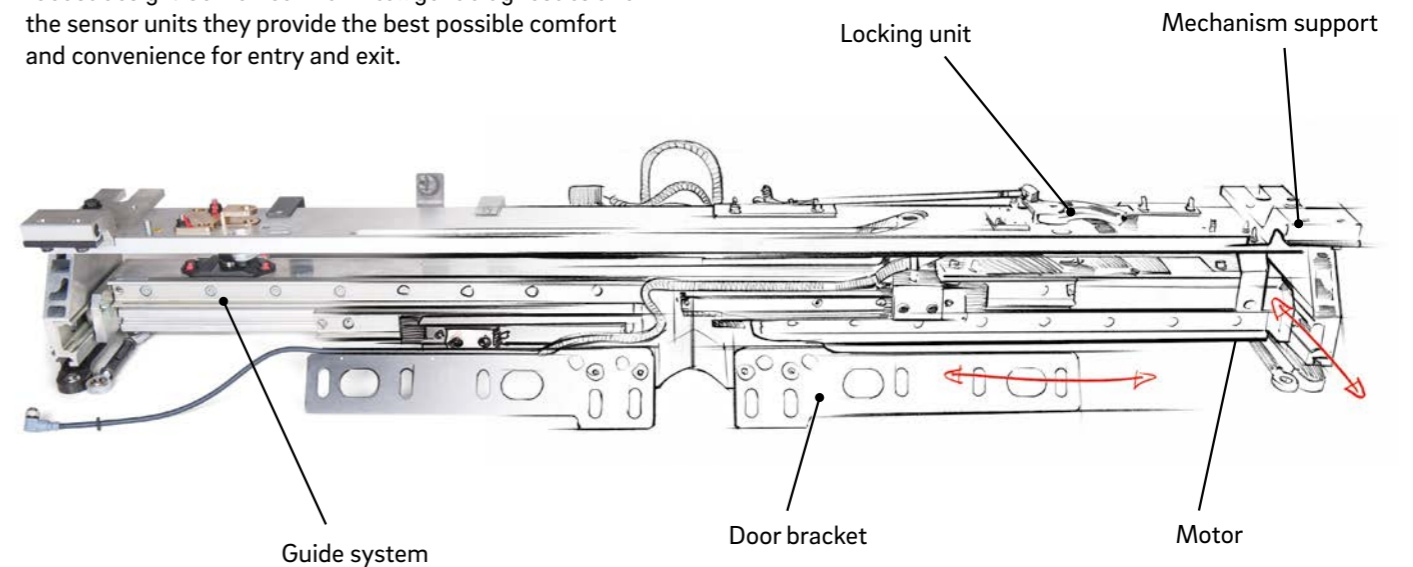

## Locking units

We select the type of locking unit depending on your specific requirements and the loads to be absorbed. Depending on the requirement we secure the door system via a locking column, a lockable swivel arm or a rotary latch lock. The systems are tried and tested and provide optimum safety.

Clear width:	1,300 – 1,950 mm
Drive:	electric, toothed belt
Energy consumption per operation: (opening and closing)	approx. 150 Ws per cycle (incl. DCU continuous output)
Maintenance frequency:	approx. 120,000 cycles
Use:	Regio, Metro, LRV
Locking unit:	Over center by means of: Rotary latch via push-pull Bowden cables / locking column / lockable swivel arm
Control unit:	24V / 36V / 72V / 110V
Diagnostics:	USB / ethernet
Sensors:	BMU / electric sensitive edges and light barrier / light grid, motor current sensing and time-path sensor

Locking column



Lockable swivel arm



Rotary latch



# BMS. Bode Metro System.

## Sliding door systems.

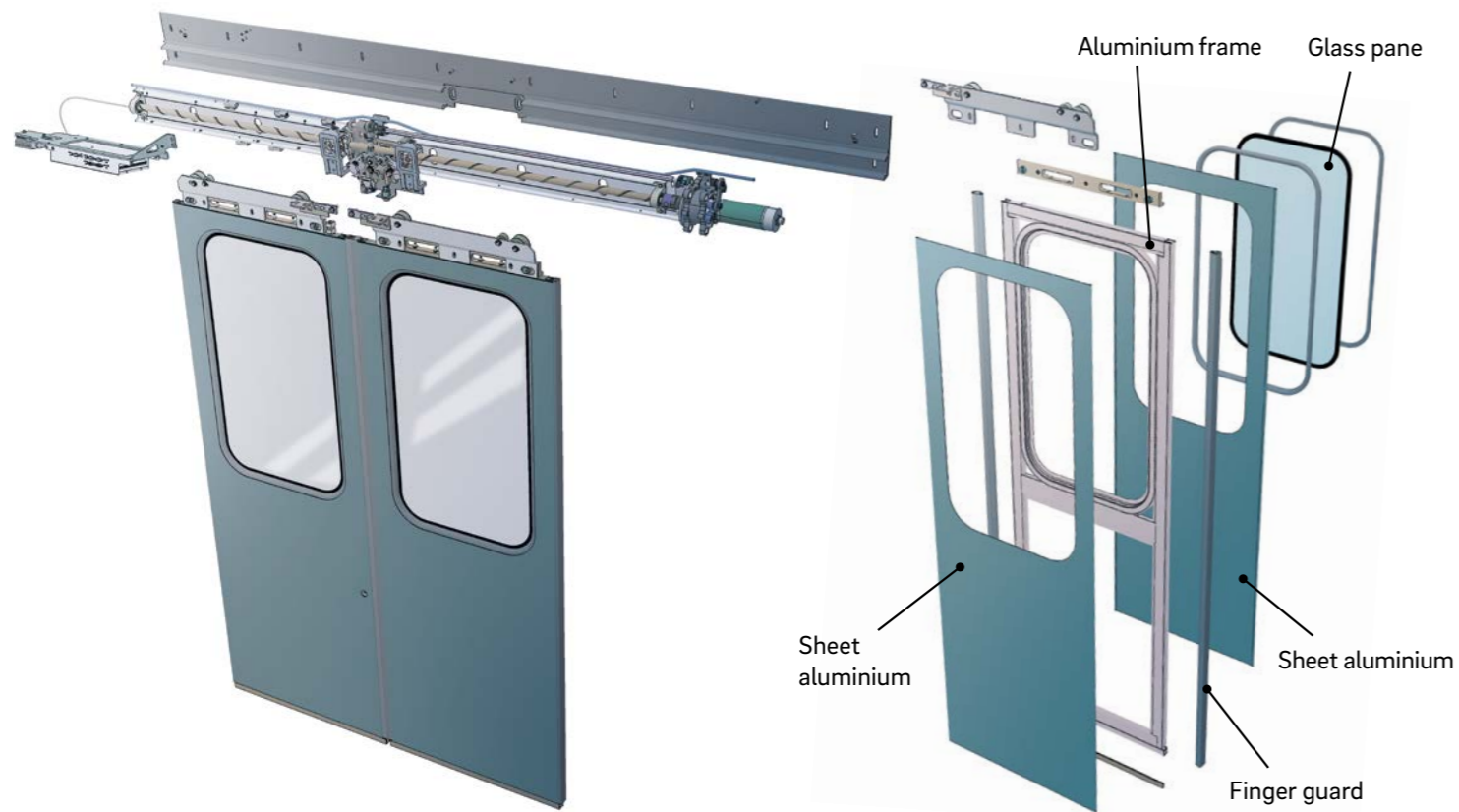

### BMS Sliding door system

The Bode Metro sliding door system can be supplied as a single and double panel sliding door with electric drive via a spindle or a toothbelt. Our BMS system is available as a pocket sliding and external sliding door.

### Sandwich door panel

The sandwich design of the door panels enables all kinds of different window shapes. Very good thermal and sound insulation values can be achieved by using additional insulation materials in the door panel configuration.

### Mechanism

The drive of our BMS system is based on a spindle or toothbelt unit. It is characterised by minimum installed dimensions and few mechanical elements. This drive is thus robust and reliable running, even under extreme loads and is in use around the world in numerous metro and light rail system vehicles.

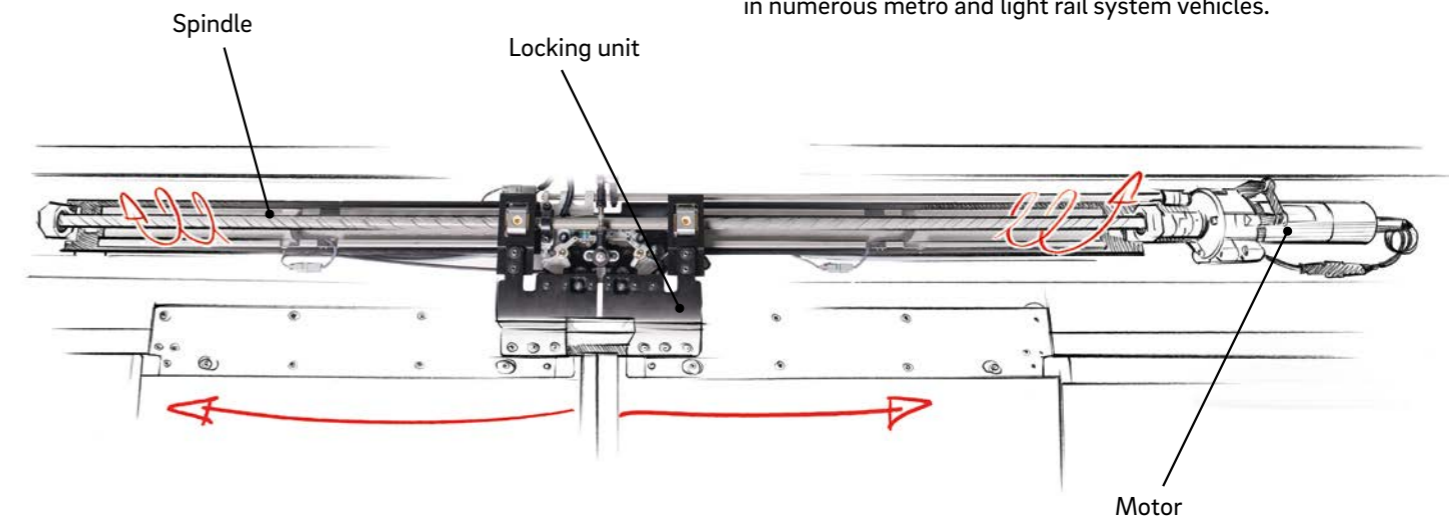

### Locking unit

The core of the door drive is the locking unit which is implemented by means of the over center position by the pivot-mounted drive motor and can thus be operated with almost no maintenance.

Clear width:	800 – 1,600 mm
Drive:	electric, spindle / toothed belt
Energy consumption per operation: (opening and closing)	approx. 120 Ws per cycle (incl. DCU continuous output)
Maintenance frequency:	approx. 150,000 cycles
Use:	LRV, Metro, Regio
Locking unit:	Rotary latch
Control unit:	24V / 36V / 72V / 110V
Diagnostics:	USB / ethernet
Sensors:	BMU / electric sensitive edges and light barrier / light grid, motor current sensing and time-path sensor

Locking unit closed



Locking unit open

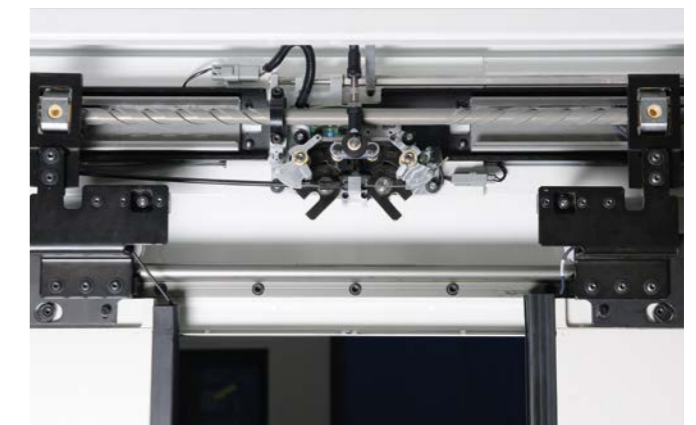

# BISS.

## Standardised sliding step systems.

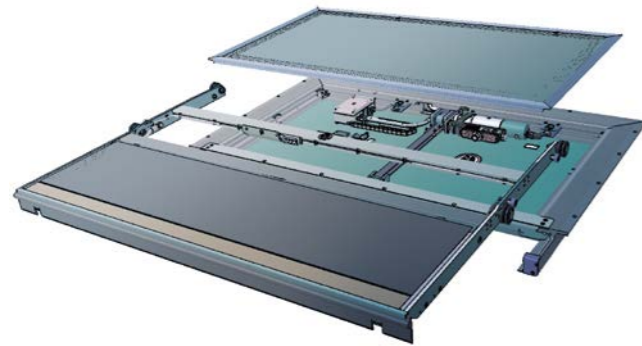

BISS sliding ramp

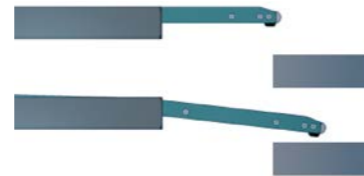

BISS sliding-stroke step

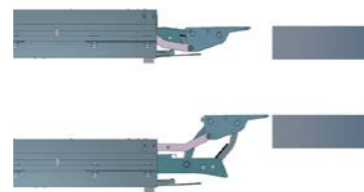

BISS sliding step with stairs

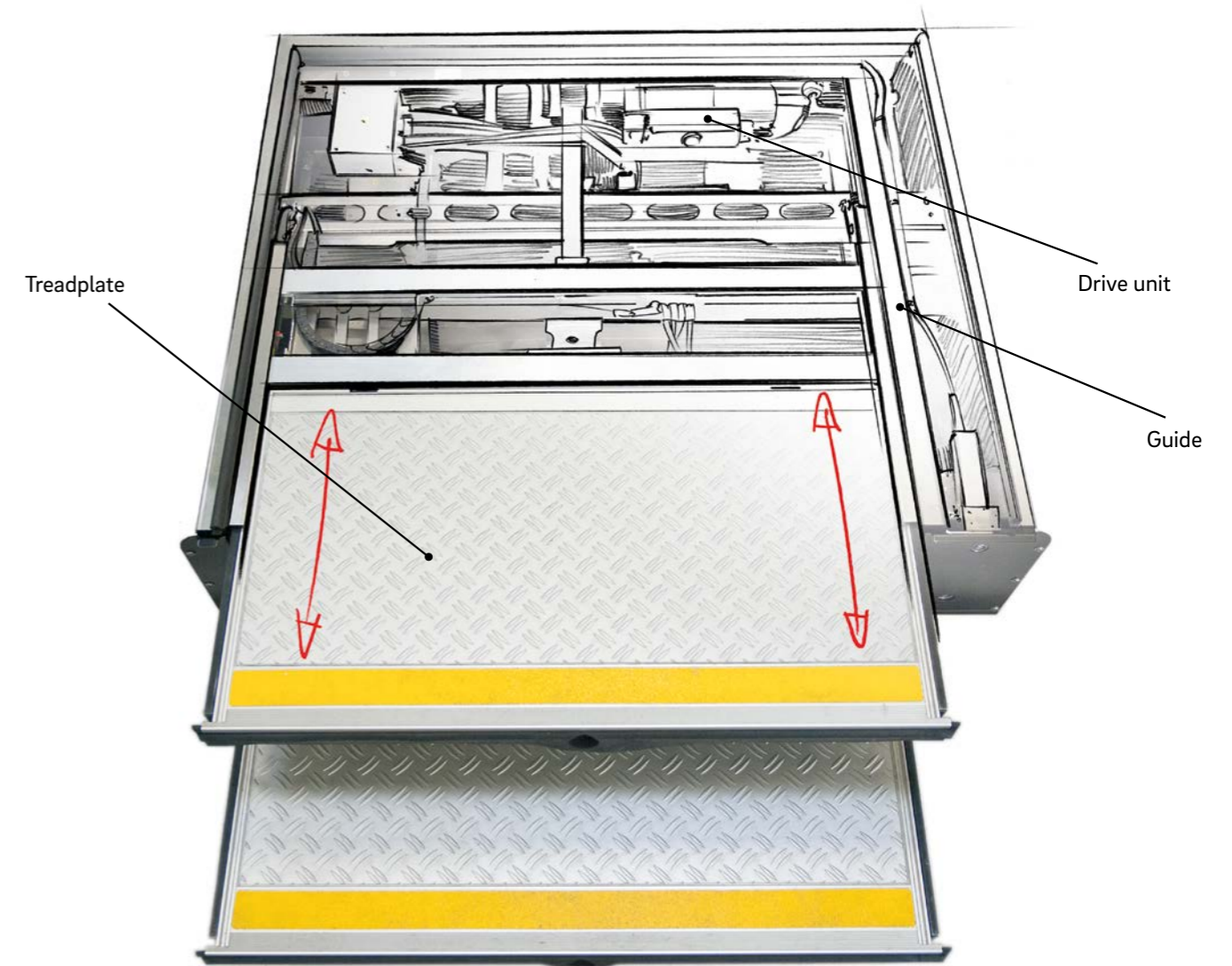
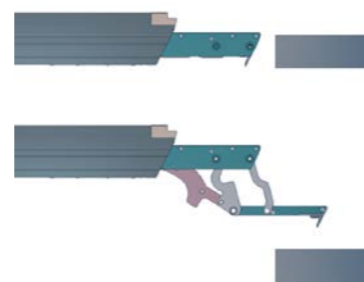

### BISS

#### Sliding step system

The BISS sliding step systems have a convincingly clear and structured layout of the drive and locking components. The patented locking concept has proven its everyday practicality, even under the most extreme conditions. As an interoperability component, the BISS sliding steps are delivered with the required TSI certificate.

#### Versions

Depending on your requirements, our sliding step systems adapt optimally to the platform edge. Automatically too, thanks to a sensor for non-contact platform detection. This has been further refined in recent years.

#### Installation options

BISS sliding step systems, as single or double step, can be inserted flat into the floor or can be installed underneath the floor through to an underframe step, which is positioned underneath the longitudinal beam of the vehicle. We use our tried and tested modules to put together a suitable system to match your requirements.

Width:	600 – 1,950 mm
Extended distance:	100 – 650 mm
Drive:	electric, toothed belt
Energy use per operation: (opening and closing)	approx. 120 Ws per cycle (incl. DCU continuous output)
Maintenance frequency:	approx. 120,000 cycles
Use:	LRV, Metro, Regio, IC, HGV
Locking unit:	Safety locking switch
Control unit:	24V / 36V / 72V / 110V
Diagnostics:	USB / ethernet
Sensors:	Load detection, platform detection, motor current sensing / BMU and time-path sensor

Sliding step system retracted



Sliding step system extended (open)

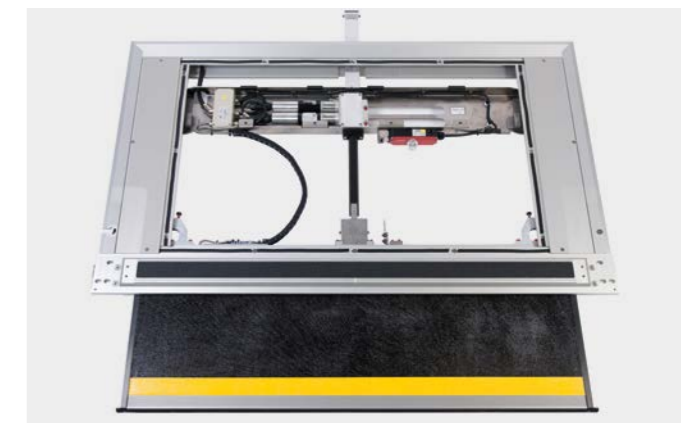

# Intelligent systems.

The purpose of well thought-through diagnostics is to avoid failures – and we are masters at this. Yet the future of the door is as an intelligent interface with the passenger and freight.

We recognised the relevance of IT in the door system many years ago and set up our own IT department. Our controls and diagnostic tools can be used under Windows and with standard hardware. The interfaces are therefore also simple and reliable: via USB and on request via an ethernet link. In addition, supplied with a simple, clear and intuitive user interface, our systems are available in more than 15 languages.

In future sensors on doors will not only carry out control functions. From ticketing through to space management, we are working on many features which will make the door system of tomorrow more intelligent.

Non-contact sensor technology for different functions in the door system is in principle already a standard feature and can be retrofitted. Whatever the future brings – Bode. Die Tür. This much is certain.

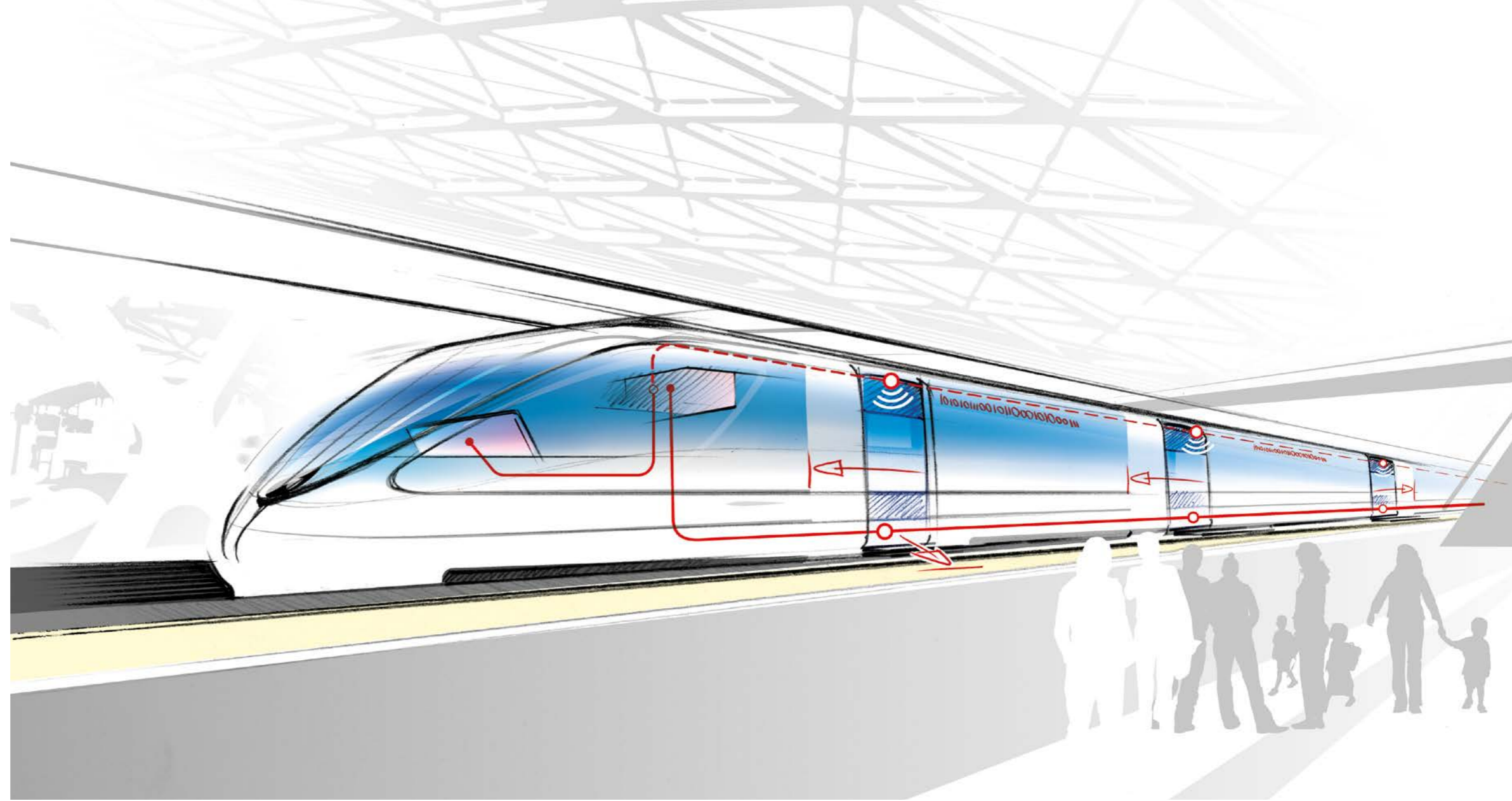

## HARDI diagnostics

Our HARDI diagnostics software analyses and documents operation of the door system simply and graphically. Key indicators are worked up visually. Over the years our programmers have optimised this tool to perfection.

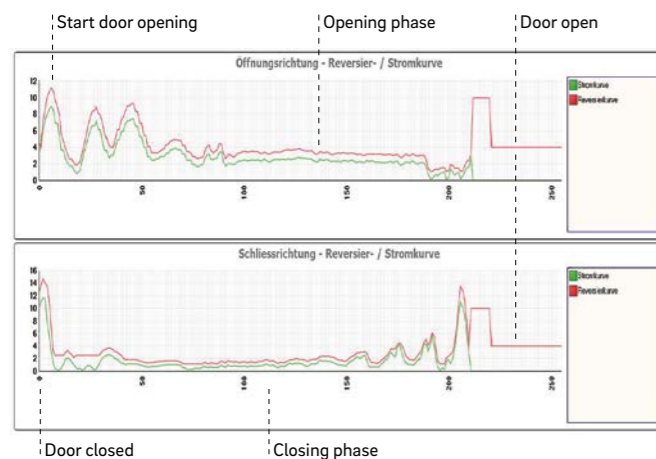

## MTB-X control unit

The control unit is the heart of a door system. With our MTB-X we offer a high degree of operational reliability and operate all standard interfaces. With two hardware versions we can also fulfil all voltage requirements, from 24 to 110 volt.



## BMU boarding management unit

As part of the Schaltbau Group we research and develop new applications for every aspect of the door system of the future. From guiding passengers to ticketing through to object detection, much is possible to make travel more pleasant, comfortable and safer – starting from the door system as the intelligent mediator between the passenger and vehicle. In cooperation with universities and institutions, we will expedite the development of intelligent networked systems. Our most important ideas and incentive come from our customers, our service department and, last but not least, passengers. We are therefore in discussion with passenger associations, to maintain a reliable feel for the wishes of the end users.

The objective of the Bode boarding management unit is to reduce the number of electric interfaces in a door system and to increase interaction between the vehicle and passenger. The new Bode sensor system, which can replace all controls and safety devices to date with only two sensors, is a prime example of this. The new Bode sensor system

secures the basic functions of the door system in the vicinity of the door, conveniently and wear-free, and provides additional safety through early detection of passenger motivations. With this system we meet the standard we have set ourselves of covering all relevant functions with few sensors and to be open to new tasks.

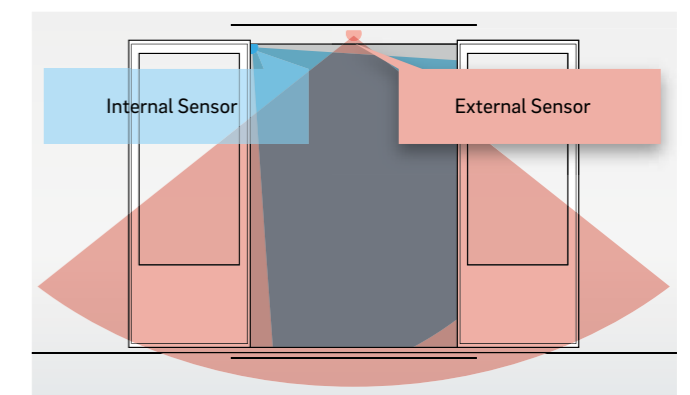



## Door systems. for mobile spaces.

This much is certain.

By rail or by road – door systems from “Bode. Die Tür.” are in use worldwide. Reliable, robust and increasingly intelligently networked, we design the interface with the passenger.

For a good 50 years we have defined the interface with the passenger. By rail, by road and wherever our experience can offer a safe system. Safety is a good cue. On the one hand for passenger safety and on the other for reliable operation. The systems must be robust and yet at the same time lightweight in order to be energy optimised and meet the high requirements set.

From the initial development through to industrial production in small and large series – many brands trust our knowledge and our quality. An excerpt from our reference list is given on the right.





# Made. by. Bode. Die Tür.

With German engineering and efficient industrial production, we implement door systems for vehicles all over the world. Despite the high degree of product, software and process standardisation, for us it is not a contradiction to actively maintain a culture which can be called mid-sized family – grown over a good 50 years. Many of our employees are second generation family members to work for Bode. You can feel this bond in our company through the commitment and enthusiasm of our workforce – a door is the first moment in which you experience the quality of a vehicle. Having a decisive role in this quality makes us proud.

Our development department falls back on many solutions which, once reinterpreted, are suitable for different tasks. From the hatch door of a car through to the fully-networked door system in a high-speed train. We have the knowledge, acquired from many worldwide projects and markets.

Our goal is failure-free door systems. Intelligent networked systems help to use materials and energy sparingly and far-sightedly. Maintenance is signalled before wear can cause a failure. Sensors ensure greater safety and provide important feedback for personnel and transport operators.

This intelligence, combined with robust lightweight construction in increasingly compact versions, enables us to perform reliable life-cycle cost calculations. A fast-response worldwide service department is on hand. Just-in-time deliveries of complete systems – ready-assembled for fast and reliable installation – to us these are obvious requirements.

From our headquarters in Kassel we transport our standards and know-how to our branches on all continents.

As part of the Schaltbau Group we understand vehicles integrally – one reason why we understand our customers so well.



Around 3,000 employees in the parent Group  
of which around 1,600 in the Bode Group

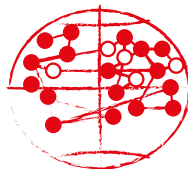

31 locations worldwide in total  
6 production facilities in the Bode Group



3 business units  
1,000 synergies

Gebr. Bode GmbH & Co. KG  
Ochshäuser Str. 14  
34123 Kassel  
Germany

Phone +49 561 5009-0

[www.schaltbau-bode.com](http://www.schaltbau-bode.com)

